

## Specifications and types

Suction fittings	2"1/2 f BSPP or DN 65 on request
Delivery fittings	2" m BSPP or DN 50 on request
Max. flow rate	75 m <sup>3</sup> /h
Max. head	38 m
Viscosity up to	500 cps
Standard open impeller	Ø 176 mm H 13 mm -10° *
Solids passing	Ø max 11 mm

\* Special versions are available on request for the fluid pumped



PLASTIC MATERIAL  
PP



PLASTIC MATERIAL  
PVDF

## STANDARD ELECTRIC MOTOR:

Kw	11
HP	15
Constructive form	B5
RPM	2900
<b>Three-phase 400/690 V</b>	-
50/60 Hz	-
2 poles	-
Efficiency class	IE3
Protection	IP55
Ambient temperature	-30°C + 45°C
Aluminium/Cast iron	-
ATEX	on request

STD COLUMN LENGTH	PP WEIGHT*	PVDF WEIGHT*
500 mm	31 Kg	33 Kg
800 mm	34 Kg	36 Kg
1000 mm	36 Kg	38 Kg
1250 mm	39 Kg	41 Kg

\* The weights refer to the pump without the motor  
NB: Special executions only on request with column length from min. 400 mm to max. 1400 mm

## OPERATING TEMPERATURES\*\*:

PP (with glass additive)	0°C to + 70°C
PVDF (with carbon additive)	-10°C to + 100°C

\*\*Measurements should be taken with agitated water; temperatures may vary depending on the conditions of the system and/or the processed liquid

LENGTH	Tmax (PP)	Tmax (PVDF)
500 mm	70	100
800 mm	65	95
1000 mm	60	90
1250 mm	55	85

## Specifications and types

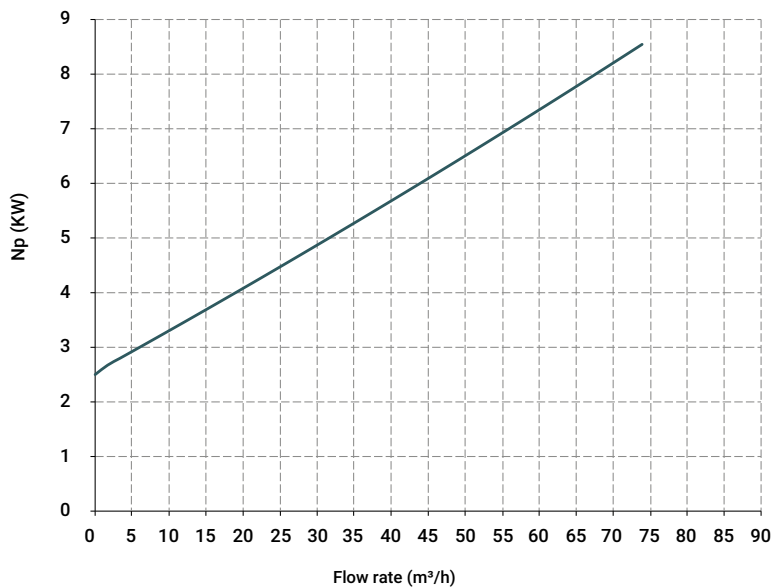
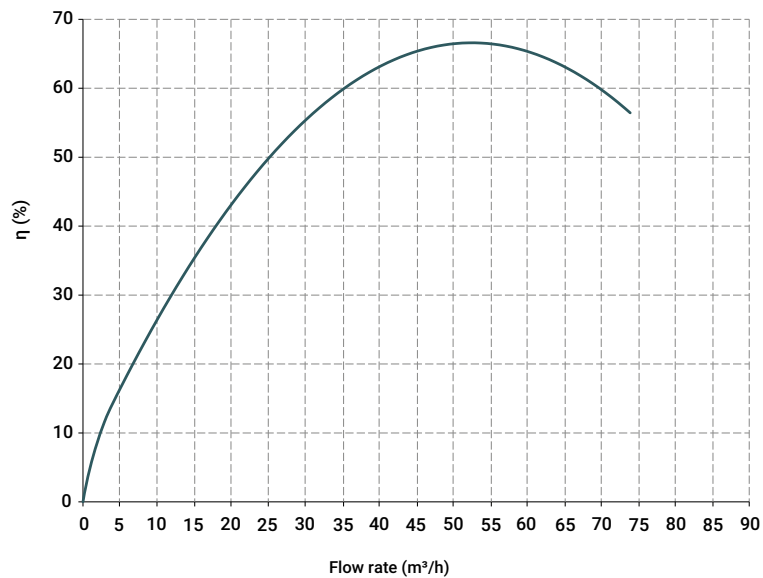
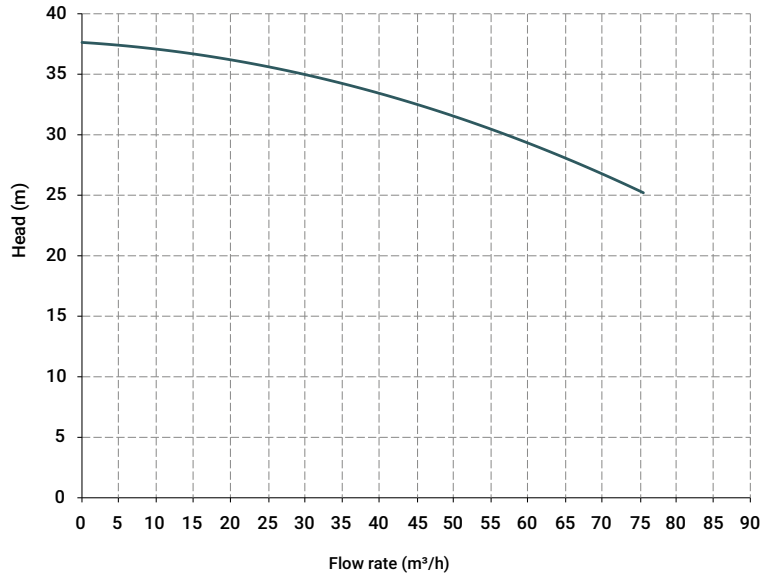

The curves and performances refer to tested pumps, with water at 20 °C, two-pole motor 50 Hz (2900rpm).

## Specifications and types

Length measurements in mm

MODEL	POWER	Ø SPASSING SOLIDS	SOVEM ENGINE: A-B	A*	B	C	D	E	F	G	H	I	M	N	O	P	MOTOR WEIGHT [kg]
IM180	11 Kw - 15 HP	11	503	806	303	25	130	480	170	215	95	380	430	215	330	275	99

\* Measurements may vary depending on the motor supplier.

L [mm]

500
800
1000
1250

L1 [mm]

300
600
800
1050

50 mm - Max Fluid Level

### Pump

IM 80

IM 90

IM 95

IM 110

IM 120

IM 130

IM 140

IM 150

IM 155

IM 160

**IM 180**

IM 200

### Motor Power

0.37 Kw - 0.5 HP

0.55 Kw - 0.75 HP

0.75 Kw - 1 HP

1.1 Kw - 1.5 HP

1.5 Kw - 2 HP

2.2 Kw - 3 HP

3 Kw - 4 HP

4 Kw - 5.5 HP

5.5 Kw - 7.5 HP

7.5 Kw - 10 HP

**11 Kw - 15 HP**

18.5 Kw - 25 HP

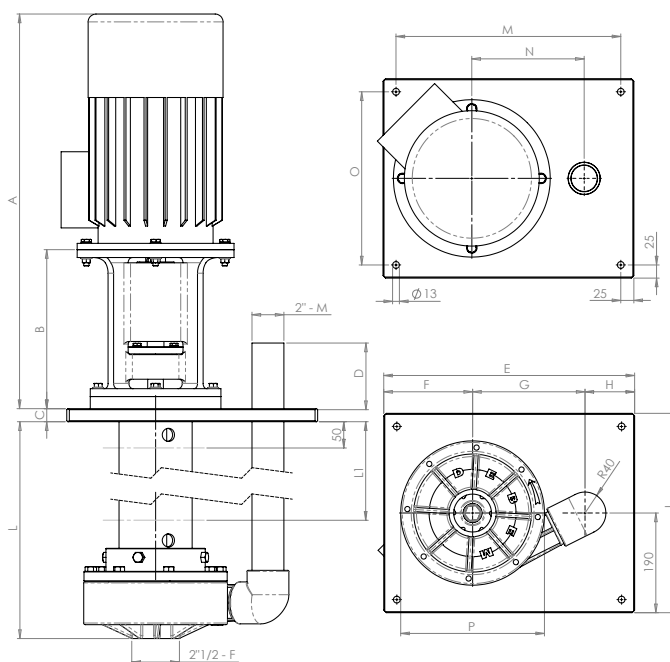

### Seal o-ring materials

- EPDM
- VITON®

### Packaging

- wooden cage - dimensions and weights vary depending on the length of the pump

### Accessories

- FLANGE KIT (DIN standard - ANSI on request)
- PP pump protection filter\* (\*Filter sold separately)
- PVDF pump protection filter\* (\*Filter sold separately)
- Customisable fixing plate only at the design stage



TANK USE