

Pressure Control Valves

Pressure Reducing Valves RP 810

Pilot-operated Pressure Reducing Valve



Technical Data

Connection DN	40 - 400
Nominal Pressure PN	16 - 160
Inlet Pressure	up to 160 bar
Outlet Pressure	1 - 40 bar
K _{vs} -Value	20 - 900 m ³ /h
Temperature	130 °C
Medium	liquids and gases

Description

Self-acting pressure reducers are simple control valves offering accurate control while being easy to install and maintain. They control the pressure downstream of the valve without requiring pneumatic or electrical control elements.

The RP 810 pressure reducing valve is a pilot-controlled control valve consisting of a main valve, a pilot valve complete with restrictor assembly and built-in strainer mounted on the cover of the main valve, non-return valve and restrictor valves. The valve cone can be fitted with a soft or metallic seal.

When the pipeline is depressurised the main valve is kept closed by a preloaded spring. When the outlet pressure is below the set pressure the pilot valve is kept open by its spring. The control medium can flow towards the valve outlet. Restrictor D1 produces a pressure drop causing the outlet pressure to be almost equal to the pilot pressure in the main valve piston. The inlet pressure overcomes the outlet pressure and closing force of the spring and opens the main valve.

As soon as the outlet pressure has reached the set pressure, the pilot valve restricts the flow. This causes the pilot pressure to rise and push the main valve piston into a controlling position. The restrictors D1 and D2 are used to optimise the control characteristics. The bypass fitted with a non-return valve ensures quick closing.

When the outlet pressure exceeds the set pressure the pilot valve closes. The pilot pressure is equal to the inlet pressure. The main valve closes as the piston diameter is greater than the valve seat. The spring also forces the valve to close.

The valve is piped internally. The pulse lines must be installed on-site.

These valves are no shut-off elements ensuring a tight closing of the valve. In accordance with DIN EN 60534-4 and/or ANSI FCI 70-2 they may feature a leakage rate in closed position in compliance with the leakage classes III or V.

Standard

- » Pilot valve made of stainless steel
- » Throttle block with integrated strainer and throttle valves completely made of stainless steel

Options

- » Version for gases
- » Hard-faced valve cone and seat
- » Special versions on request

Operating instructions, know how and safety instructions must be observed. The pressure has always been indicated as overpressure. We reserve the right to alter technical specifications without notice.

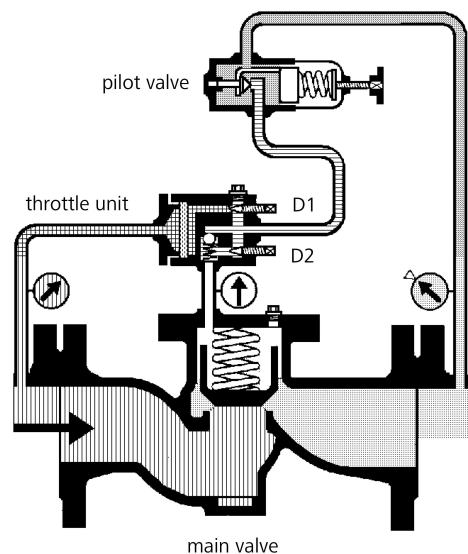

K _{vs} -Values [m ³ /h]						
nom. diam. DN	40	50	65	80	100	125
K _{vs} -value m ³ /h	20	32	50	60	70	150

K _{vs} -Values [m ³ /h]						
nom. diam. DN	150	200	250	300	350	400
K _{vs} -value m ³ /h	250	350	500	600	700	900

Setting Ranges [bar], Nominal Pressure			
1 - 5	4 - 12	10 - 20	15 - 40
PN 16-160/10	PN 16-160/16	PN 16-160/40	PN 16-160/63

Pressure Control Valves

Pressure Reducing Valves RP 810

Pilot-operated Pressure Reducing Valve



Materials

Temperature	80 °C	130 °C
Body	PN 16	spheroidal cast iron or cast steel
	PN 160	cast steel
	PN 16 - 160	stainless steel
Cover	steel optional stainless steel	
Internals	chromium steel optional stainless steel	
Valve Seal	NBR	EPDM
O-Ring	NBR	EPDM
Pilot Valve, Throttle Unit	stainless steel	stainless steel

Dimensions [mm]

nominal pressure PN	size	nominal diameter DN					
		40	50	65	80	100	125
16	A*	200	230	290	310	350	400
40	A*	200	230	290	310	350	400
63 - 160	A*	260	300	340	380	430	
alle PN	B	200	220	250	260	280	290
alle PN	C	140	160	180	220	220	230

Dimensions [mm]

nominal pressure PN	size	nominal diameter DN					
		150	200	250	300	350	400
16	A*	480	600	730	850	980	1100
40	A*	480	600	730	850	980	
63 - 160	A*	550	650				
alle PN	B	330	390	420	550	550	550
alle PN	C	240	270	290	350	350	410

* Overall length tolerances in acc. with DIN EN 558

Weights [kg]

nominal pressure PN	nominal diameter DN											
	40	50	65	80	100	125	150	200	250	300	350	400
16	25	30	40	50	70	120	150	210	380	450	520	625
40	33	38	48	65	80	140	160	240	440	510	580	
63 - 160	40	45	55	80	110		165	290				

Customs Tariff Number

84811019

Special designs on request.

The pressure has always been indicated as overpressure.

Mankenberg reserves the right to alter or improve the designs or specifications of the products described herein without notice.

Dimensional Drawing

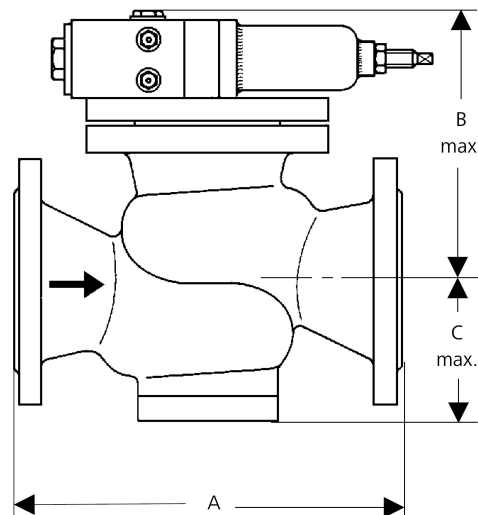

Recommended Installation

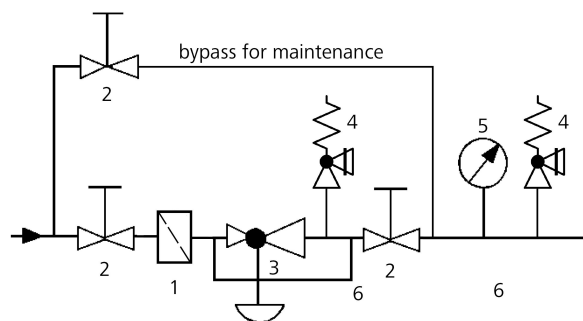

- 1 Strainer*
- 2 Shut-off Valves
- 3 Pressure Reducer*
- 4 Safety Valves*
- 5 Pressure Gauge
- 6 Sense Line G 1/2

Sense line connection 10 x DN before and behind the valve

*Use MANKENBERG-Products