



FUEL MANAGEMENT SYSTEMS



DISPENSERS



KITS



PUMPS



METERS



NOZZLES

DRUM

FEATURES

- EASY TO INSTALL
- SUITABLE FOR ALL DRUMS
- DIFFERENT PUMPS FOR ANY NEED
- AC/DC VERSIONS

The PIUSI DRUM is a compact fuel transfer unit suitable to be connected on drums thanks to the quick 2" coupling. Available with different pumps, the system is (always) equipped with a telescopic suction hose and the nozzle holder located above the drum, near the pump, for easy, clean and safe operations. K33 mechanical meter available on request.

PERFORMANCE

UP TO
80 L/MIN

FLOW RATE

AC/DC
VOLTAGE

POWER

± 1%

ACCURACY



DRUM BIPUMP 12V



DRUM PANTHER 56 K33

PACKAGING

CODE		WEIGHT		PACKAGING		
WITHOUT METER	WITH METER	KG	LBS	MM	INCH	PCS/BOX
OO0271POO	OO0272POO	13,5	29,8	48OX37OX265	18,3X14,6X10,4	1
OO0273POO	OO0274POO	14,4	31,7	48OX37OX265	18,3X14,6X10,4	1
FO022201A	FO022205A	20,7	45,6	48OX37OX265	18,3X14,6X10,4	1
FO022202A	FO022206A	20,7	45,6	48OX37OX265	18,3X14,6X10,4	1
FO022203A	FO022207A	21,6	47,6	48OX37OX265	18,3X14,6X10,4	1
FO022204A	FO022208A	21,6	47,6	48OX37OX265	18,3X14,6X10,4	1
-	FO034111C	14,7	31,7	48OX37OX265	18,3X14,6X10,4	1



FILTRATION



TANK MONITORING



HOSE REEL



ACCESSORIES



MERCHANDISE

AD
ANY BIODIESEL

A
AIR

A
ANTIFREEZE

Ad
AdBlue®

B
BIODIESEL

D
DIESEL

F
FOOD

G
GASOLINE

G
GREASE

K
KEROSENE

O
OIL

W
WATER

W
WINDSCREEN

CHART

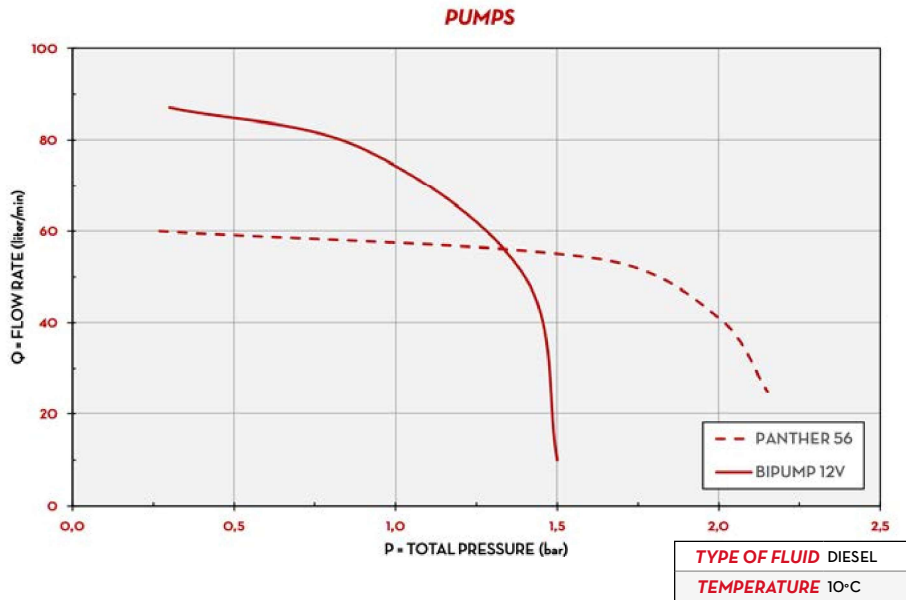

DIMENSIONS

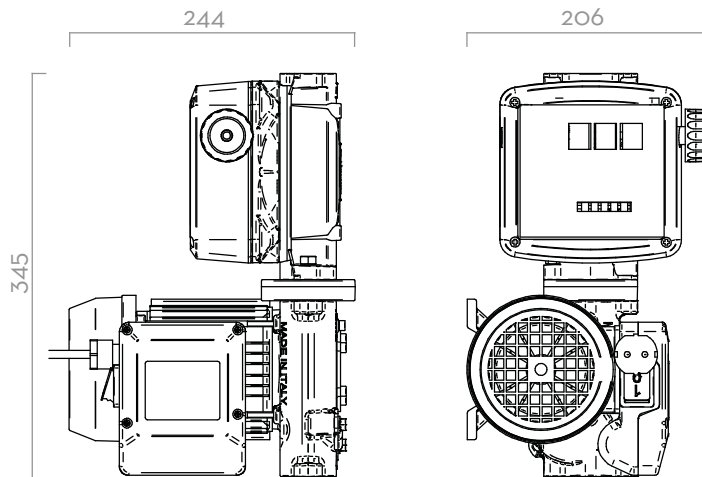

Dimensions expressed in millimeters

IN THE BOX

- PUMP
- TELESCOPIC SUCTION PIPE
- DELIVERY HOSE
- NOZZLE
- 2" CONNECTOR
- K33 MECHANICAL METER (ON REQUEST)
- INSTRUCTION MANUAL

DETAILS



2" CONNECTOR



TELESCOPIC SUCTION HOSE



ELECTRIC CABLE WITH CLAMPS (ONLY DC VERSION)

COMPONENTS

- **PUMPS:**
 PANTHER AC PAG. 100
 BIPUMP PAG. 118
 PANTHER DC PAG. 116
- **METER:**
 K33 PAG. 148

TECHNICAL DATA

CODE		DESCRIPTION	FLUIDS TYPE	FLOW RATE		VOLTAGE			METER	NOZZLE	INLET	HOSE
WITHOUT METER	WITH METER			L/MIN	GPM	AC V./HZ DC VOLT	POWER WATT	AMP. MAX.				
000271P00	000272P00	DRUM PANTHER 56	D	56	15	230/50	350	3	K33	SELF2000	3/4"	4M
000273P00	000274P00	DRUM PANTHER 56 A60	D	56	15	230/50	350	3	K33	A60	3/4"	4M
FOO22201A	FOO22205A	DRUM BIPUMP 12V	D	80	21	12V	530	44	K33	SELF2000	1"	4M
FOO22202A	FOO22206A	DRUM BIPUMP 24V	D	80	21	24V	540	22,5	K33	SELF2000	1"	4M
FOO22203A	FOO22207A	DRUM BIPUMP 12V A120	D	80	21	12V	530	44	K33	A120	1"	4M
FOO22204A	FOO22208A	DRUM BIPUMP 24V A120	D	80	21	24V	540	22,5	K33	A120	1"	4M
-	FOO34111C	DRUM PANTHER DC 24/12V K33 A60	D	56	15	24/12V	150	25/16A	K33	A60	3/4"	4M