



FUEL MANAGEMENT SYSTEMS



DISPENSERS



KITS



PUMPS



METERS



NOZZLES

# ST

## FEATURES

- **RADY TO USE**
- **EASY TO INSTALL**
- **STURDY STRUCTURE**
- **COMPACT DEISGN**
- **AVAILABLE WITH DIFFERENT PUMPS**

The PIUSI ST is a versatile and compact diesel transfer station that can be used to fill mobile tanks or interact with distribution units. It is fitted with check valve, filter, nozzle and 4mt delivery hose. Its sturdy structure makes this dispenser suitable to be used in the harshest environments. It can be integrated with a protective metal box and water separating filter.

### PERFORMANCE

UP TO  
**90 L/MIN**

FLOW RATE

**AC/DC**  
VOLTAGE

POWER

**4MT**  
LENGTH

DELIVERY HOSE



ST



### PACKAGING

CODE	WEIGHT		PACKAGING		
	KG	LBS	MM	INCH	PCS/BOX
000266P00	16	35	357X357X275	14,1X14,1X10,8	1
000286P00	16	35	357X357X275	14,1X14,1X10,8	1
000266P20	21	46	357X357X275	14,1X14,1X10,8	1
000214000	21	46	357X357X275	14,2X14,2X11,8	1
000216000	23	50	480X370X265	18,9X14,6X10,4	1
000252000	23	50	480X370X265	18,9X14,6X10,4	1
FO021000B	10	22	357X357X275	14,1X14,1X10,8	1
FO021100B	10	22	357X357X275	14,1X14,1X10,8	1
FO0340080	19	42	357X357X275	14,1X14,1X10,8	1



FILTRATION



TANK MONITORING



HOSE REEL



ACCESSORIES



MERCHANDISE

B

ANY BIODIESEL

A

AIR

A

ANTIFREEZE

Ad

AdBlue®

B

BIODIESEL

D

DIESEL

F

FOOD

G

GASOLINE

G

GREASE

K

KEROSENE

O

OIL

W

WATER

W

WINDSCREEN

### AVAILABLE WITH DIFFERENT PUMPS



AC PUMP - PANTHER



AC PUMP - E80



AC PUMP - E120



AC PUMP - VISCOMAT VANE



DC PUMP - BP3000



DC PUMP - PANTHER DC

### DIMENSIONS

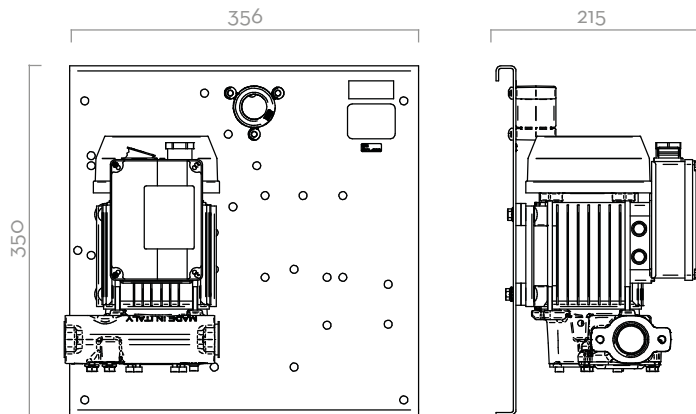

Dimensions expressed in millimeters

### IN THE BOX

- ST UNIT
- DELIVERY HOSE
- NOZZLE
- NOZZLE HOLDER
- INSTRUCTION MANUAL

### DETAILS



MANUAL NOZZLE



AUTOMATIC NOZZLE

### COMPONENTS

- **PUMPS:**
  - PANTHER AC PAG. 100
  - E80/E120 PAG. 104
  - VISCOMAT VANE PAG. 102
  - BP3000 PAG. 114
  - PANTHER DC PAG. 116
- **NOZZLE:**
  - MANUAL NOZZLE PAG. 164
  - AUTOMATIC NOZZLE PAG. 160

### TECHNICAL DATA

CODE	DESCRIPTION	FLUIDS TYPE	FLOW RATE		VOLTAGE			METER	NOZZLE	FILTER	DELIVERY HOSE		OUTLET	
			L/MIN	GPM	AC V/ HZ DC VOLT	POWER WATT	AMP. MAX.				TYPE	LENGTH	Ø	bsp
000266P00	ST PANTHER 56	D	56	15	230/50	350	3	NO	SELF 3000	NO	4M	3/4"	1"	
000286P00	ST PANTHER 56 A60	D	56	15	230/50	350	3	NO	A60	NO	4M	3/4"	1"	
000266P20	ST PANTHER 72/M	D	72	19	230/50	500	4.2	NO	SELF 3000	NO	4M	3/4"	1"	
000214000	ST E 80	D	80	21	230/50	700	3,5	NO	SELF 3000	NO	4M	1"	1"	
000216000	ST E 120	D	90	24	230/50	1150	5,7	NO	SELF 3000	NO	4M	1"	1"	
000252000	ST E 120 A120	D	90	24	230/50	1150	5,7	NO	A120	NO	4M	1"	1"	
FO021000B	ST BYPASS 3000 12V	D	42	11	12	260	22	NO	SELF 3000	NO	4M	3/4"	1"	
FO021100B	ST BYPASS 3000 24V	D	42	11	24	300	12	NO	SELF 3000	NO	4M	3/4"	1"	
FO0340080	ST PANTHER DC 12V	D	56	15	12	420	35	NO	SELF 3000	NO	4M	3/4"	1"	

THE UNIT CAN ALSO BE SUPPLIED FOR OPERATING UNDER DIFFERENT VOLTAGES AND WITHOUT METER.