



FUEL MANAGEMENT SYSTEMS



DISPENSERS



KITS



PUMPS



METERS



NOZZLES

# ST WITH METER

## FEATURES

- **READY TO USE**
- **EASY TO INSTALL**
- **STURDY STRUCTURE**
- **HIGH PRECISION METER**
- **AVAILABLE WITH DIFFERENT PUMPS**

The PIUSI ST WITH METER is a diesel transfer station for fixed installations composed by AC or DC pump, nozzle (manual or automatic) and precision meter - both mechanical (K33) or electronic (K600 B/3) - for safe and controlled refueling operations. Easy to install, this station can be used to fill mobile tanks or interact with distribution units.

### PERFORMANCE

UP TO  
**90 L/MIN**

FLOW RATE

**AC/DC**  
VOLTAGE

POWER

**± 1%**

ACCURACY

**4MT**  
LENGTH

DELIVERY HOSE



ST WITH METER



METALLIC BOX (optional)



### PACKAGING

CODE	WEIGHT		PACKAGING		
	KG	LBS	MM	INCH	PCS/BOX
FOO385POA	16	35	357X357X275	14,1X14,1X10,8	1
FOO287POA	16	35	357X357X275	14,1X14,1X10,8	1
OOO390OOO	21	46	357X357X275	14,1X14,1X10,8	1
OOO392OOO	23	50	357X357X275	14,2X14,2X11,8	1
OOO395OOO	23	50	480X370X265	18,9X14,6X10,4	1
OOO395O5O	24	53	480X370X275	18,9X14,6X11,8	1
OOO397OOO	20	44	480X370X265	18,9X14,6X10,4	1
OOO287P4O	19	41	357X357X275	14,1X14,1X10,8	1
FOO235OOB	13	29	357X357X275	14,1X14,1X10,8	1
FOO236OOB	13	29	357X357X275	14,2X14,2X11,8	1
FOO233OOB	14	31	480X370X265	18,9X14,6X10,4	1
FOO234OOB	14	31	480X370X265	18,9X14,6X10,4	1
FOO240OOA	24	53	357X357X275	14,1X14,1X10,8	1
FOO240O3A	24	53	357X357X275	14,1X14,1X10,8	1
FOO241OOA	24	53	357X357X275	14,1X14,1X10,8	1
FOO241O1A	11	11	357X357X275	14,1X14,1X10,8	1
FOO340O7O	17	37	357X357X275	14,1X14,1X10,8	1
FOO34016O	17	11	357X357X275	14,1X14,1X10,8	1



FILTRATION



TANK MONITORING



HOSE REEL



ACCESSORIES



MERCHANDISE



ANY BIODIESEL



AIR



ANTIFREEZE



AdBlue®



BIODIESEL



DIESEL



FOOD



GASOLINE



GREASE



KEROSENE



OIL



WATER



WINDSCREEN

### AVAILABLE WITH DIFFERENT PUMPS



AC PUMP - PANTHER 56/72



AC PUMP - E80/E120



AC PUMP - VISCOMAT 70/90



DC PUMP - BYPASS 3000



DC PUMP - PANTHER DC



DC PUMP - BIPUMP

### DIMENSIONS

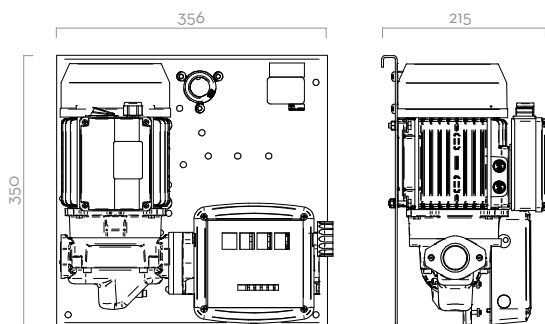

Dimensions expressed in millimeters

### IN THE BOX

- ST WITH METER UNIT
- METER
- DELIVERY HOSE
- NOZZLE
- NOZZLE HOLDER
- INSTRUCTION MANUAL

### DETAILS



K33 / K600 B/3



MAN. / AUTOM. NOZZLE

### COMPONENTS

- **PUMPS:**
  - PANTHER AC PAG. 100
  - E80/E120 PAG. 104
  - VISCOMAT VANE PAG. 102
  - BP3000 PAG. 114
  - PANTHER DC PAG. 116
  - BIPUMP PAG. 118
- **NOZZLE:**
  - MANUAL NOZZLE PAG. 164
  - AUTOMATIC NOZZLE PAG. 160
- **METERS:**
  - K33 PAG. 148
  - K600 B/3 PAG. 138

### TECHNICAL DATA

CODE	DESCRIPTION	FLUIDS TYPE	FLOW RATE		VOLTAGE			METER	NOZZLE	SUCTION HOSE	HOSE		OUTLET
			L/MIN	GPM	AC V/HZ	DC VOLT	POWER WATT				AMP. MAX.	LENGTH (M)	
FOO385POA	ST PANTHER 56 K33	D	56	15	230/50	350		K33	SELF 3000	NO	4	20	3/4"
FOO287POA	ST PANTHER 56 K33 A60	D	56	15	230/50	350		K33	A60	NO	4	20	3/4"
OOO390000	ST E80 K33	D	80	21	230/50	700	3,5	K33	SELF 3000	NO	4	25	1"
OOO392000	ST E80 K33 A80	D	75	20	230/50	700	3,5	K33	A80	NO	4	25	1"
OOO395000	ST E120 K33	D	90	24	230/50	1150	5,7	K33	SELF 3000	NO	4	25	1"
OOO395050	ST E120/M K44	D	90	24	230/50	1150	5,7	K44	SELF 3000	NO	4	25	1"
OOO397000	ST E120 K33 A120	D	90	24	230/50	1150	5,7	K33	A120	NO	4	25	1"
OOO287P40	ST PANTHER 72/M K33 A80	D	72	19	230/50	500	4,2	K33	A80	NO	4	25	1"
FOO23500B	ST BYPASS 3000/12V K33	D	40	10	12	260	22	K33	SELF 3000	NO	4	20	3/4"
FOO23600B	ST BYPASS 3000 INLINE 24V K33	D	40	10	24	300	12	K33	SELF 3000	NO	4	20	1/4"
FOO23300B	ST BYPASS 3000/12V K33 A60	D	35	9	12	260	2	K33	A60	NO	4	20	3/4"
FOO23400B	ST BYPASS 3000 INLINE 24V K33 A60	D	35	9	24	300	12	K33	A60	NO	4	20	3/4"
FOO24000A	ST BIPUMP 12V K33 SELF 3000	D	80	21	12	530	44	K33	SELF 3000	NO	4	25	1"
FOO24003A	ST BIPUMP 12V K33 A120	D	80	21	12	530	44	K33	A120	NO	4	25	1"
FOO24100A	ST BIPUMP 24V K33 SELF 3000	D	80	21	24	540	22,5	K33	SELF 3000	NO	4	25	1"
FOO24101A	ST BIPUMP 24V K33 A120	D	80	21	24	540	22,5	K33	A120	NO	4	25	1"
FOO340070	ST PANTHER 12V K33 A60	D	56	15	12	420	35	K33	A60	NO	4	20	3/4"
FOO340160	ST PANTHER DC 12/24V K33 A60	D	70/35	18,5/9,2	24/12	420/150	25/16	K33	A60	NO	4	20	3/4"

## ST WITH METER